

IS-120B SPOT WELDER

IS-443B SEAM WELDER

IS-444B SPOT WELDER

IS-470B SEAM WELDER

IS-471B SPOT WELDER

ISA-500A SPOT WELDER

DC TECH SERIES INVERTER POWER SUPPLIES FOR RESISTANCE WELDING APPLICATIONS



FEATURES

- *High Speed Adaptive Feedback*
- *Process Control*
- *Closed-Loop Feedback*
- *Technically Advanced Inverter Technology*
- *Shorter Weld Times*

BENEFITS

- *Produces consistent, reliable welds with optimal nugget formation, superior joint strength and excellent surface appearance*
- *Provides milli-second control over the resistance welding process*
- *A feedback rate of every 500 microseconds, maintains programmed weld current or power*
- *Improves spot and seam welding of traditionally "hard to weld" materials including coated steels, aluminum, brass and copper*
- *Compared to conventional AC welders, DC Inverter technology produces heat more efficiently, thus decreasing weld times as much as three to one and reducing the heat affected zone (HAZ)*

Miyachi, a pioneer in inverter resistance welding, now offers its complete family of DC-Tech inverter power supplies for resistance welding applications. With rated capacities up to 325kVA, DC-Tech delivers superior weld quality by utilizing lower weld currents, shorter weld times and lower weld forces than conventional AC controls. Utilizing high speed, real time, adaptive feedback control to carefully regulate weld current and heat generation, and reduce energy usage while increasing electrode life. Multiple weld monitor functions enable the user to control the resistance welding process, improve weld quality, increase production efficiency and reduce cost.



SPOT WELD POWER SUPPLIES

Typical Applications and Uses:

- Stainless and galvanized doors and furniture
- Automotive sheet metal and components
- Aluminum structural components
- Copper wire solidification
- High speed copper to galvanized cross wire welds
- Motor armature fusing

CLOSED LOOP FEEDBACK CONTROL

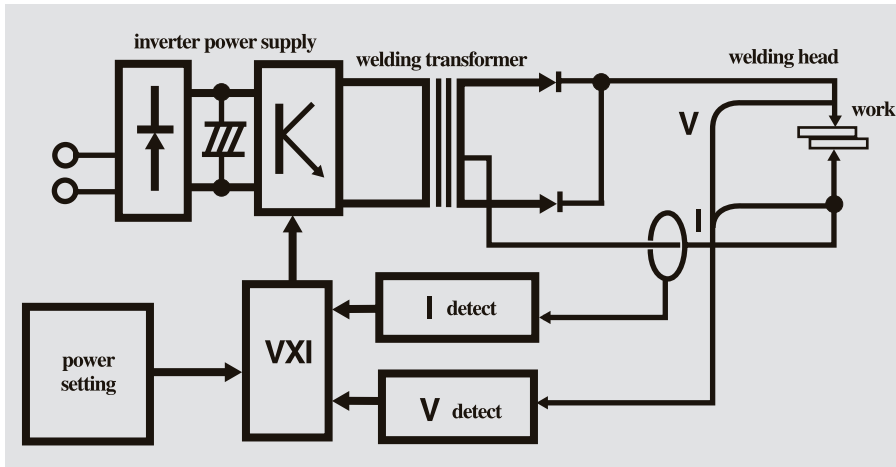

Closed-loop feedback circuit maintains programmed weld current or power (selectable by user) by measuring and adjusting secondary current and voltage. With a feedback rate of every 500 micro-seconds, consistent weld current (or power) at the electrodes is maintained, overcoming power fluctuations and material workpiece variances that hurt weld quality.



SEAM WELD POWER SUPPLIES

Typical Applications and Uses:

- Water filtration components
- Vehicle fuel tanks
- Aluminum and titanium aircraft components
- Heavy gauge wire shelving
- High speed bi-metal electrical contacts



IS-443B



IS-470B



IS-120B



ISA-500A



IS-444B



IS-471B

PROGRAMMING MADE EASY



**MA-627A
Program Unit**

**MA-628A
Monitor Unit**

- **MA-627A Remote Program Unit** – Used to store weld schedules and program multiple units.
- **MA-628A Monitor Unit** – Adds process security by displaying Current, Power, Time and Error data while inhibiting access to programming.

DC-TECH ORDERING GUIDE

System Requirements*:

- Inverter Power Supply (See back page)
- Program Unit (MA-627A)
- Toroidal Coil
- Inverter Transformer (See table below)
- Optional Monitor Box (MA-628A)

Transformer Selection Table				
Model	IT-40	IT-85	IT-130	IT-250
IS-120B (spot)	•	•		
IS-444B (spot)		•	•	
ISA-500A (spot)			•	
IS-471B (spot)			•	•
IS-443B(seam)		•	•	
IS-470B(seam)			•	•

*Each item sold separately.

See back page for complete specifications.

INVERTER WELDING DELIVERS PERFORMANCE & PAYBACK

With quality and production demands increasing, DC inverter resistance welding offers benefits that traditional AC welding cannot address; in the broadest sense, inverter welding offers more flexibility than conventional AC resistance welding. Virtually any application that can be done with an AC weld control can also be done with inverter technology.

Inverter Performance Benefits

Many resistance weld failures can be traced to inconsistent secondary welding current. Adaptive feedback systems used in inverter technology utilize pulse width modulation to continuously monitor and adjust the weld current throughout the weld, compensating for non-uniform workpiece resistance, worn electrodes, and power source fluctuations, resulting in extremely consistent weld current delivery throughout every weld. The benefits derived include shorter weld times, lower currents and forces, faster speed and throughput, longer electrode life, less weld splash and less part (surface) deformation.

Efficient Weld Current Delivery Improves Quality

In resistance welding, a weld joint (or nugget) is formed as weld current flows through the workpieces, encounters different electrical resistances and generates heat. AC controls, by definition, cycle weld current on and off twice per cycle. This AC “cycling” can cause embrittlement and irregular nugget formation, hurting weld quality and strength. By contrast, inverter systems deliver current without cycling, thus continuously heat the weldments. Weld times can be adjusted in one millisecond increments. This precise control allows inverter welders to utilize shorter weld times and control how current is introduced to the parts; that is to say, to shape the current waveform. As a result, lower weld current and less force (compared to an AC weld control) can be utilized to achieve the desired molten state of the weldments for optimal nugget formation.

Hard to Weld Materials

Inverters are capable of successfully welding a broad range of materials. Softer metals, particularly those with high electrical and thermal conductivity are good candidates for inverter resistance welding. High electrical conductivity means that higher welding currents must be used. High thermal conductivity requires that the weld current must be delivered quickly to minimize the heat affected zone. Zinc-coated galvanized steels also fall into this category.

Transformer Size & High Current Output

Compact inverter equipment features small, lightweight welding transformers for use in manual, automated and robotic (transgun) configurations. In AC resistance welding, higher current outputs typically require extremely large transformers. The physical size and weight of the AC welding transformer is especially critical in transgun configurations, often limiting the current output available. Inverter transformers are often as much as 50% smaller, lighter, and deliver higher current outputs than conventional AC transguns.

Inverter Realities

Inverter performance benefits can result in higher production rates with less time lost to electrode maintenance and changes. According to many manufacturers, weld failures, part rejects, and costly re-work have been dramatically reduced. Shorter weld times, lower weld currents and balanced line loads lessen the primary current demand also reducing electrical usage and expense. Adaptive feedback control modes and millisecond programming make precise control over the resistance welding process a reality. DC inverter welding allows for a broader process window to overcome workpiece variances and production challenges. This larger process window is one of the primary reasons that inverter welding meets today’s demand for higher quality and delivers such attractive returns on investment.

SPECIFICATIONS

POWER SUPPLY MODEL	Spot Weld			Seam/Roll Spot	
	IS-120B	IS-444B	ISA-500A	IS-471B	IS-443B
Power Source	3 phase 480VAC / 440VAC / 400VAC / 220VAC +10% -15% 50/60 Hz.				
Output Frequency	1 kHz / 800 Hz / 600Hz (selectable)				
Output Voltage	Single phase 650V, peak @ 480V input				
Rated Capacity	52kVA @ 480 VAC	182kVA @ 480 VAC	325kVA @ 480 VAC	182kVA @ 480 VAC	325kVA @ 480 VAC
Max. Primary Output Current	200A (8% duty cycle)	500A (15% duty cycle)	1000A (12% duty cycle)	500A (15% duty cycle)	1000A (12% duty cycle)
Control Systems	Secondary Constant Current Secondary Constant Power Primary Constant Current (RMS) Primary Constant Current (Peak) Fixed Pulse Secondary Constant Voltage	Secondary Constant Current Secondary Constant Power Primary Constant Current (RMS) Primary Constant Current (Peak) Fixed Pulse		Primary Constant Current (PWM RMS Value) Primary Constant Current (PWM Effective Peak) Fixed Pulse	
Control Modes	n/a	Forging, Chaining, Successive		n/a	
Weld Schedules	15 schedules		15 schedules		7 schedules
Timer Settings	<i>ms Mode</i> <i>Cycle Mode</i>	<i>ms Mode</i>		<i>Cycle Mode</i>	<i>ms Mode</i>
Squeeze Delay	0000-9999ms 000-999cyc	0000-9999ms		000-999cyc	n/a
Squeeze Delay	0000-9999ms 000-999cyc	0000-9999ms		000-999cyc	0000-9999ms
Delay	n/a n/a	n/a		n/a	000-999ms
Weld 1	000-600ms 00-30cyc	000-600ms		00-30cyc	000-600ms
Upslope	000-400ms 00-20cyc	000-400ms		00-20cyc	000-400ms (included in Weld 1)
Cool	000-999ms 00-99cyc	000-999ms		00-99cyc	000-999ms
Weld 2	000-600ms 00-30cyc	000-600ms		00-30cyc	n/a
Downslope	000-400ms 00-20cyc	000-400ms		00-20cyc	n/a
Hold	000-999ms 00-99cyc	000-999ms		00-99cyc	000-999ms
Off	0000-9990ms 00-99cyc	0000-9990ms		00-99cyc	n/a
Pulses	1-9 1-9	1-9		1-9	1-9
Max. Secondary Current Settings	0.1 - 20.0kA	2.0 - 40.0kA	4.0 - 80.0kA	1.0 - 20.0kA	2.0 - 40.0kA
Weld Monitors					
Current	00.0-20.0kA	00.0-40.0kA	00.0-80.0kA	00.0-20.0kA	00.0-40.0kA
Voltage	00.0-9.99V	0.00-9.99V	0.00-9.99V	n/a	n/a
Power	00.0-20.0kW	00.0-40.0kW	00.0-80.0kW	n/a	n/a
Pulse Width	10%-100%	10%-100%	10%-100%	10%-100%	10%-100%
Program Unit	MA-627A (sold separately)				
Monitor Unit	MA-628A (sold separately)			n/a	
Physical Characteristics					
Dimensions Inches H x W x D (mm)	11.0 x 7.00 x 25.0 (279 x 178 x 635)	27.0 x 12.0 x 20.0 (686 x 305 x 508)	27.0 x 12.0 x 26.0 (686 x 305 x 660)	27.0 x 12.0 x 20.0 (686 x 305 x 508)	27.0 x 12.0 x 26.0 (686 x 305 x 660)
Weight: lbs (kg)	33 (15)	99 (45)	139 (63)	99 (45)	139 (63)
Transformer Model	IT-40	IT-85	IT-130	IT-250	
Rated Capacity	40kVA @ 50%	85kVA @ 50%	130kVA @ 50%	250kVA @ 50%	
Max. Input Voltage	650V	650V	650V	650V	
Input Frequency	1000 Hz	1000 Hz	1000 Hz	1000 Hz	
Unloaded Secondary Voltage/Turns Ratio	4.28V (152:1), 8.55V (76:1)	8.9V (73:1), 9.5V (68:1)	13.0V (50:1), 13.8V (41:1)	13.0V (50:1)	
Cooling Water	1 gal/per min.	2 gal/per min.	4 gal/per min.	4 gal/per min.	
Dimensions Inches (H x W x D) (mm)	6.75 x 5.00 x 14.9 (171 x 127 x 378)	6.75 x 6.00 x 11.9 (171 x 152 x 302)	10.3 x 6.00 x 15.5 (262 x 152 x 394)	10.3 x 7.75 x 19.0 (262 x 197 x 483)	
Weight lbs. (Kg)	60 (27)	60 (27)	110 (50)	130 (59)	

Your Local Representative



A Unitek Miyachi Group Company

- **Corporate Office:** 245 E. El Norte St. • P.O. Box 5039 • Monrovia, CA 91017-7139 USA
Tel: (626) 256-4128 • FAX: (626) 303-5396 • E-Mail: info@miyachi1.com
Internet http://www.miyachi1.com
- **Europe:** Miyachi Technos Europe GmbH • Pleidelsheimer Str. 11, D-74321 Bietigheim, Germany
Tel: (49) 07142-97520 • FAX: (49) 07142-975227
- **Japan:** Miyachi Technos • 3F Koyosha Bldg., 5-48-5, Higashinippori, Arakawa-ku, Tokyo 116-0014, Japan
Tel: (81) 3-3891-2211 • Fax: (81) 3-3891-7887
- **Korea:** Miyachi Technos • 4F Donam Bldg., 362-4 Yangje-dong, Seocho-gu, Seoul, Korea
Tel: +2-3461-6061 • +2-3461-6062 • +2-3461-6063 • Fax: +2-3461-4045
- **China:** Miyachi Trading (Shanghai) Co., LTD. • RmC 7F Eastern Business Bldg., No.586 Pan Yu Road, Shanghai, 200052 China • Tel: (201) 6283-5657 • Fax: (201) 6283-8606

Specifications subject to change without notice.

Copyright ©2001 Unitek Miyachi Corporation, a Unitek Miyachi International Company. The material contained herein cannot be reproduced or used in any other way without the express written permission of Unitek Miyachi Corporation. All rights reserved.